

# Rotary Measuring Technology

## Incremental encoders

### Economy Type 5810 (shaft)



- ø 58 mm housing
- Short-circuit proof outputs
- Customized versions also available
- High mechanical protection
- Push-pull output  
(10 ... 30 V supply voltage)



#### Mechanical characteristics:

Speed:	max. 6000 min <sup>-1</sup>
Rotor moment of inertia:	approx. 0.6 x 10 <sup>-6</sup> kgm <sup>2</sup>
Starting torque:	< 0.01 Nm
Radial load capacity of shaft:	40 N
Axial load capacity of shaft:	20 N
Weight:	approx. 0.4 kg
Protection acc. to EN 60 529:	IP 64 Housing (IP 67 with cable, IP 50 with connector)
EX approval for hazardous areas:	optional zone 2 and 22
Working temperature:	0° C ... +65 °C
Shaft:	stainless steel
Shock resistance acc. to DIN-IEC 68-2-27	1000 m/s <sup>2</sup> , 6 ms
Vibration resistance acc. to DIN-IEC 68-2-6:	100 m/s <sup>2</sup> , 10...2000 Hz

#### Electrical characteristics:

Output circuit:	Push-pull
Supply voltage:	10 ... 30 V DC
Power consumption (no load)	
without inverted signal:	max. 80 mA
Permissible load/channel:	max. ±30 mA
Pulse frequency:	max. 20 kHz
Signal level high:	min. U <sub>B</sub> – 2.5 V
Signal level low:	max. 1.5V
Rise time t <sub>r</sub>	max. 1 µs
Fall time t <sub>f</sub>	max. 1 µs
Short circuit proof outputs: <sup>1)</sup>	yes
Reverse connection protection at UB:	yes
Conforms to CE requirements acc. to EN 61000-6-2, EN 61000-6-4 and EN 61000-6-3	
RoHS compliant acc. to EU guideline 2002/95/EG	

<sup>1)</sup> If supply voltage correctly applied

#### Terminal assignment

Signal:	0 V	+U <sub>B</sub>	A	B	0 or 0̄	Shield
5 pin plug, Pin:	1	2	3	4	5	PH <sup>1)</sup>
Colour	WH	BN	GN	YE	GY	

<sup>1)</sup> PH = Shield is attached to connector housing

Isolate unused outputs before initial startup.

#### Top view of mating side, male contact base:

5-pin plug

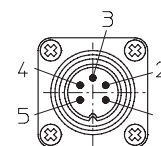

### Economy Type 5810 (shaft)

#### Dimensions

Clamping flange  $\varnothing 58$

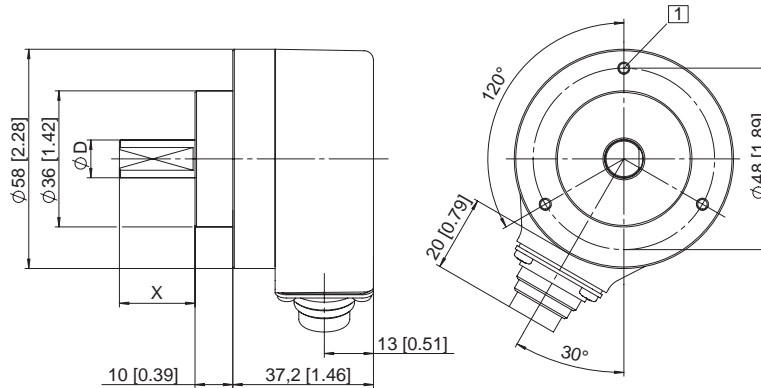

Synchronous flange  $\varnothing 58$

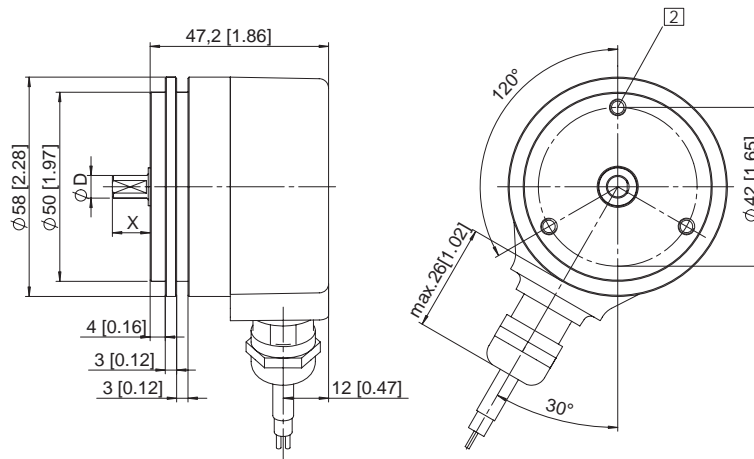

1 3xM3, 6 [0,24] deep

2 3xM4, 6 [0,24] deep

#### Mounting advice:

The flanges and shafts of the encoder and drive should not both be rigidly coupled together at the same time! We recommend the use of suitable couplings (see Accessories section).

#### Order code:

**8.5810.XXXX.XXXX**

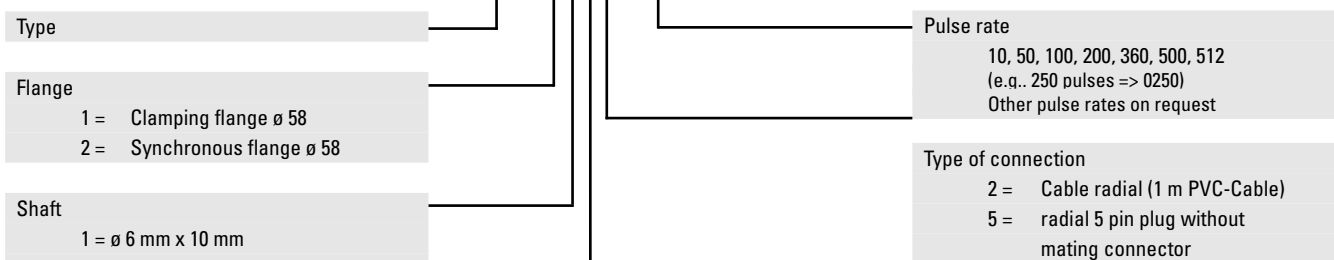

Preferred types are indicated in **bold**

#### Accessories:

Corresponding mating connector of connection type 5: Order-No. 8.0000.5022.0000

Cables and connectors, also pre-assembled, can be found in the chapter Connection Technology

Mounting attachments and couplings can be found in the chapter Accessories