

### Miniature Type 2400 (shaft) / 2420 (hollow shaft)



- Wide temperature range (-20 ... +85 °C)
- Sturdy cable outlet with multiple clamping
- Temperature compensation
- Broad input voltage range (5 ... 24 V or 8 ... 30 V)
- Highly flexible cable withstands constant flexing from 0 °C ... 70 °C)

- Low power consumption despite high scanning rate
- Short-circuit proof
- Very high EMC standard  
– Kübler encoder type 24xx meets German Railways standard EN 50121\*\*

Speed:	max. 12 000min <sup>-1</sup>
Rotor moment of inertia:	approx. 0.1 x 10 <sup>-6</sup> kgm <sup>2</sup>
Starting torque:	<0.001 Nm
Radial load capacity of shaft:	10 N
Axial load capacity of shaft:	20 N
Weight:	approx. 0.06 kg
Protection acc. to EN 60529:	IP 64 housing side, IP 64 shaft side on request
Working temperature:	-20° C ... +85 °C <sup>2)</sup>
Materials:	Shaft: stainless steel Blind hollow shaft: brass
Shock resistance acc. to DIN-IEC 68-2-27	1000 m/s <sup>2</sup> , 6 ms
Vibration resistance acc. to DIN-IEC 68-2-6:	100 m/s <sup>2</sup> , 55 ... 2000 Hz

<sup>2)</sup> Non-condensing

#### Electrical characteristics:

Output circuit:	Push-pull (7272) <sup>1)</sup>	Push-pull (7272) <sup>1)</sup>
Supply voltage:	5 ... 24 V DC	8 ... 30 V DC
Power consumption (no load):	max. 50 mA	max. 50 mA
Permissible load/channel:	max. 50 mA	max. 50 mA
Pulse frequency:	max. 160 kHz	max. 160 kHz
Signal level high:	min. U <sub>B</sub> = -2.5 V	min. U <sub>B</sub> = -3 V
Signal level low:	max. 0.5 V	max. 0.5 V
Rise time t <sub>r</sub> :	max. 1 µs	max. 1 µs
Fall time t <sub>f</sub> :	max. 1 µs	max. 1 µs
Short circuit proof outputs:	yes	yes
UL certified	File 224618	
Conforms to CE requirements acc. to EN 61000-6-2, EN 61000-6-4 and EN 61000-6-3		
RoHS compliant acc. to EU guideline 2002/95/EG		

<sup>1)</sup> Max. recommended cable length 30 m

#### Terminal assignment

Signal:	0V	+U <sub>B</sub>	A	$\bar{A}$	B	$\bar{B}$	0	$\bar{0}$	
Colour:	WH	BN	GN	YE	GY	PK	BU	RD	
without inverted signal:	WH	BN	GN		YE		GY		

Isolate unused outputs before initial start-up

#### \*\* Kübler encoder type 24xx meets German Railways standard

An independent test laboratory (TTI-P-G115/96-01) approved by the German Accreditation Council (DAR) certified the compliance with the railway standard, according to EN 50121.

This means our encoder is compatible with higher electromagnetic noise standards than standard industrial encoders. You will have a higher quality encoder even in applications with higher EMC noise levels.

We will gladly send you a copy of the test report on request. When ordering an encoder to the railway standard, please ensure you state this explicitly on the order.



### Miniature Type 2400 (shaft) / 2420 (hollow shaft)

#### Dimensions shaft version:

Flange type 1 (Ø 24 mm)

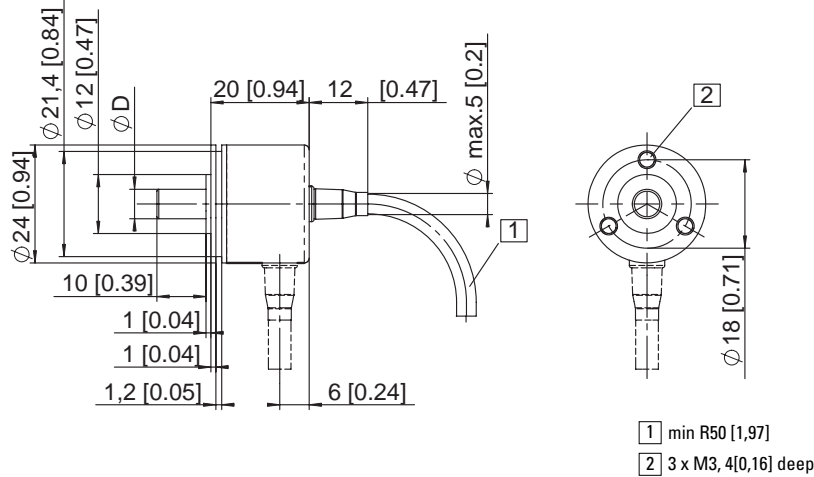

Flange type 2 (Ø 30 mm)

Flange type 3 (Ø 28 mm)

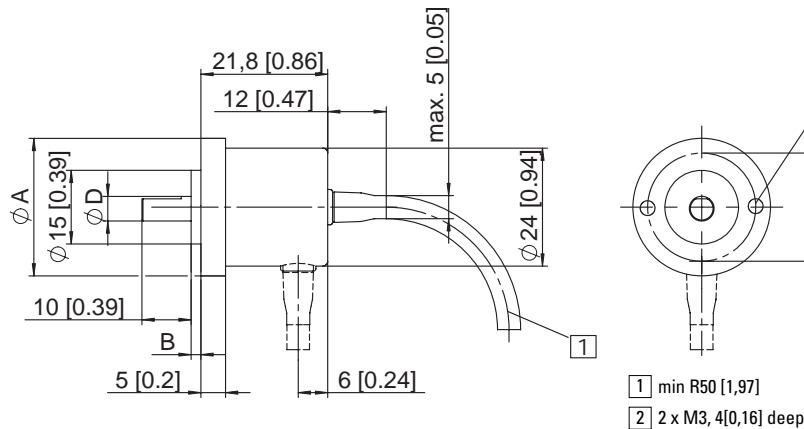

#### Mounting advice:

The flanges and shafts of the encoder and drive should not both be rigidly coupled together at the same time! We recommend the use of suitable couplings (see Accessories section).

Flange type	2	3
A	ø 30 mm	ø 28 mm
B	3 mm	2 mm

#### Order code shaft version:

05.2400.XXXX.XXXX



Type		Pulse rate	4, 6, 8, 10, 16, 20, 25, 36, 40, 50, 60, 80, 100, 120, 125, 180, 200, 250, 300, 360, 400, 500, 512, 1000, 1024 (e.g. 360 pulses=> 0360) Other pulse rates on request
Flange	1 = ø 24 mm 2 = ø 30 mm 3 = ø 28 mm further options on request	Type of connection	1 = Cable axial (2 m PVC cable ø 4.5 mm) 2 = Cable radial (2 m PVC cable ø 4.5 mm)
Shaft	1 = ø 4 mm x 10 mm 2 = ø 6 mm x 10 mm 3 = ø 5 mm x 10 mm with flattening	Output and voltage supply	1 = Push-pull (without inverted signals) 5 ... 24 V supply voltage 2 = Push-pull (with inverted signals) 5 ... 24 V DC supply voltage 3 = Push-pull (without inverted signals) 8 ... 30 V DC supply voltage 4 = Push-pull (with inverted signals) 8 ... 30 V supply voltage
Stock types	05.2400.1122.0050 05.2400.1122.0100 05.2400.1122.0360 05.2400.1122.0500 05.2400.1122.1000 05.2400.1122.1024 05.2400.3321.1000 05.2400.3341.1000 05.2400.3331.0500 05.2400.3331.1000	Accessories:	– Cables and connectors, also pre-assembled, can be found in the chapter Counting Technology – Mounting attachments and couplings can be found in the Chapter Accessories

### Miniature Type 2400 (shaft) / 2420 (hollow shaft)

Dimensions hollow shaft version:

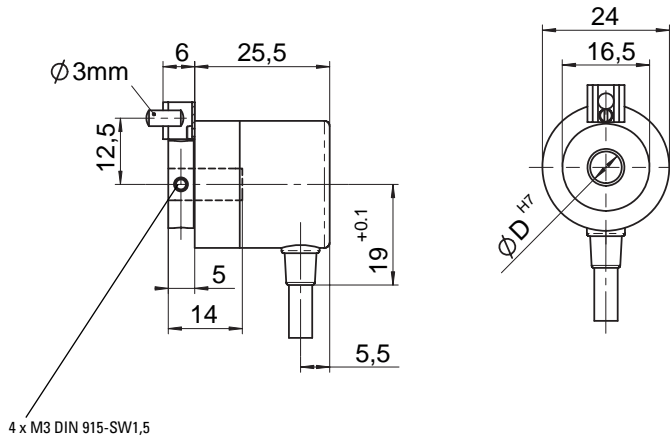

#### Mounting advice:

The flanges and shafts of the encoder and drive should not both be rigidly coupled together at the same time! A cylindrical pin (ISO 2338-A-3m6 x 10), for use as a torque stop, is supplied

Order code hollow shaft version:

05.2420.1XXX.XXXX

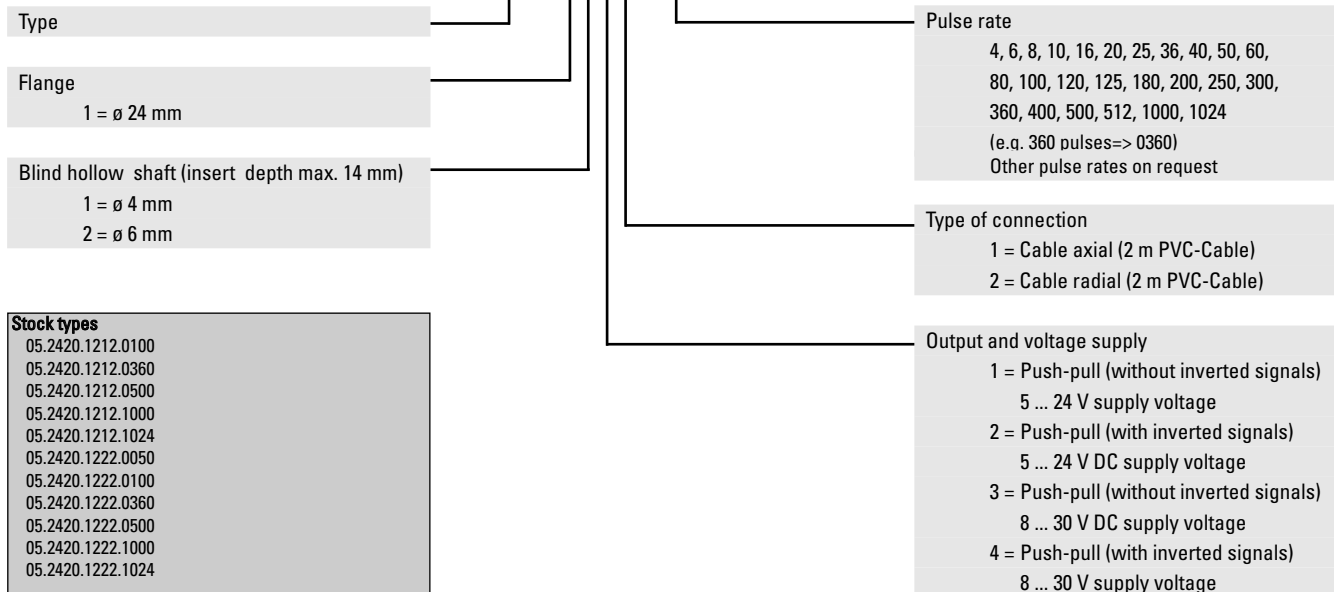

#### Stock types

05.2420.1212.0100  
05.2420.1212.0360  
05.2420.1212.0500  
05.2420.1212.1000  
05.2420.1212.1024  
05.2420.1222.0050  
05.2420.1222.0100  
05.2420.1222.0360  
05.2420.1222.0500  
05.2420.1222.1000  
05.2420.1222.1024

#### Accessories:

- Cables and connectors, also pre-assembled, can be found in the chapter Counting Technology
- Mounting attachments and couplings can be found in the Chapter Accessories